

E06-HD15M-5BNCM-XX  
 LENGTH(UNIT:FT)

L	T
L ≤ 6FT	+30/-0mm
6FT < L ≤ 10FT	+50/-0mm
10FT < L ≤ 30FT	+150/-0mm
L > 30FT	+200/-0mm

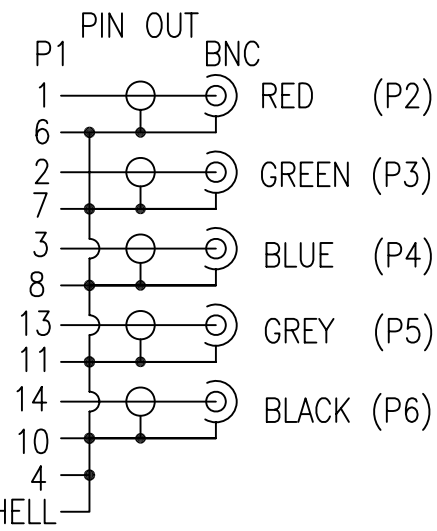

- NOTE:
- CABLE: (28AWG X 5 COAX, EACH COAX SPIRAL SHIELDED, UL1354, COLOR CODE: RED, GREEN, BLUE, GREY, BLACK), AL-FOIL AND BRAID(85%) SHIELDED WITH DRAIN, UL2919 + CUL IA FT1, BLACK PVC JACKET OD:9.0mm
  - CONNECTOR: P1: HIGH DENSITY 15PIN MALE, SOLDER TYPE, GOLD FLASH CONTACTS, BLACK PBT INSULATON, THE 9TH PIN UNLOADED. P2, P3, P4, P5, P6: BNC MALE: GOLD FLASH CONTACTS, 75 OHM .
  - THUMB SCREW TO BE MOLDED.
  - FERRITE CORE(C5A RH:  $\phi 17.5 \times \phi 10.2 \times 28.5\text{mm}$ ) TO BE MOLDED.
  - P1 SHIELDING: COPPER-FOIL TAPE COVERED PREMOLD AND 360° SOLDER TO CONNECTOR SHELL AND CABLE BRAID.
  - ALL HOOD & STRAIN RELIEF & FERRITE CORE: MOLDED BLACK PVC.
  - PACKING: EACH CABLE IN A CLEAR ZIP-LOCK POLY-BAG.
  - P1 MOLD NO:TNT-HD15-01,TNT-HD15-N01;P2~P5 MOLD NO:TNT-BNC-01



TOLERANCE			Tri-Net Technology, Inc.			
INCHES	M/M		http://www.trinetusa.com			
.X	.015	.30	SCALE	NONE	REV	A
.XX	.010	.10	UNIT	MM		
.XXX	.005	.05				
DRAWN BY			SHEET	1/1	DWG NO.	
CHECK BY			DATE	04/26/05		
APPD BY			TITLE	HD15/M TO 5BNC/M		
			PART NO.	E06-HD15M-5BNCM-XX		