

MOLDED LOGO

MOLDED LOGO

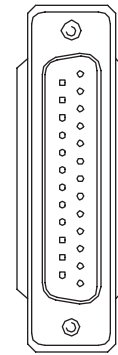
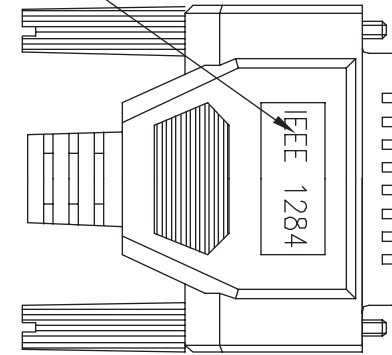
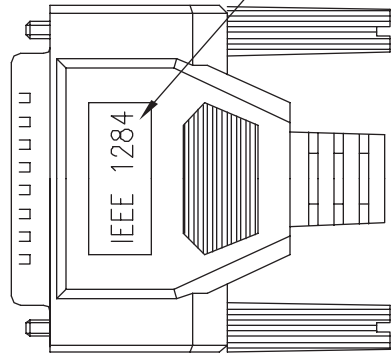
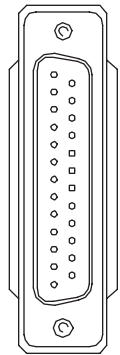

CHART 1:

P/N	L	T	XX	**
D03-D25M-D25M-06	1829	±51	6	06
D03-D25M-D25M-10	3048	±51	10	10
D03-D25M-D25M-15	4572	+152 -51	15	15



O
 S

DRAWING APPROVED _____		DATE: _____	
SAMPLE APPROVED PER DRAWING SPECIFICATIONS _____		DATE: _____	
PROPRIETARY & CONFIDENTIAL. THIS DOCUMENT MAY NOT BE COPIED, OR DISCLOSED IN WHOLE OR IN PART WITHOUT THE WRITTEN CONSENT OF TNT.			
	mm	TITLE	DB25 MALE TO DB25 MALE
SCALE	NONE	CUS. NAME	
SHEET	1/2	CUS. P/N	D03-D25M-D25M-XX
DIMENSIONAL TOLERANCES UNLESS OTHERWISE NOTED		PART NO.	P9909071-E
.X ± 0.2	.XX ±	ENG.	DATE
.XXX ±	ANGLES ±	CHECKED	DATE
REV. E	CUS. REV	APPROVED	DATE



PIN OUT

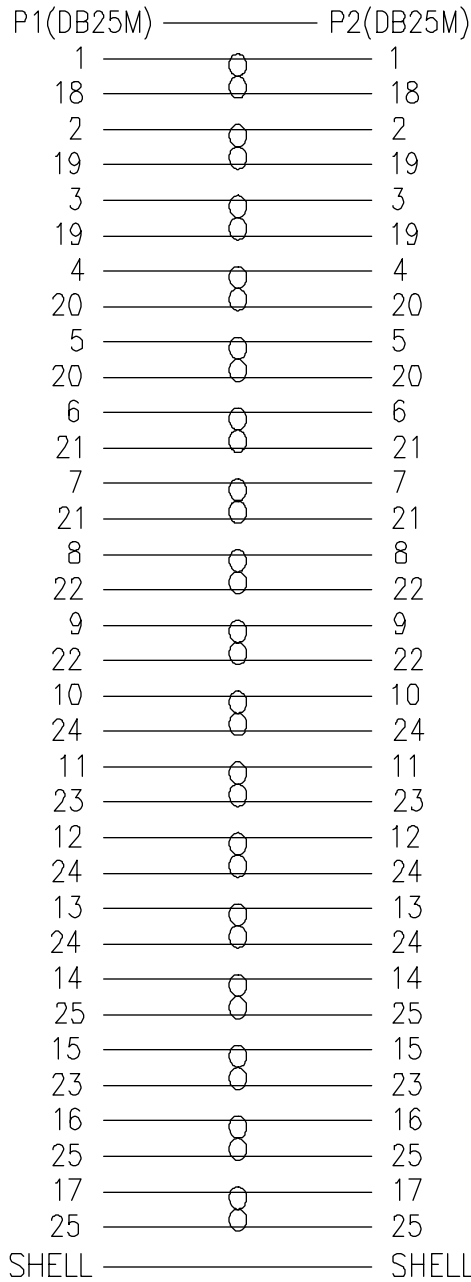

NOTE:

1. CABLE: 28AWG X 18PAIRS(INSULATION: P.P, CONDUCTOR OD= ϕ 0.62 \pm 0.05mm) UNBALANCE=62 \pm 6 OHM, 36 TO 44 TURNS PER METER, AL-FOIL AND BRAID(85%) SHIELDED WITH A DRAIN WIRE, UL20276(IEEE 1284), BEIGE(CTG-401) PVC JACKET, MARKING ON PVC JACKET INCLUDE "IEEE 1284-1994 COMPLIANT" ALONG ITS LENGTH.
2. CONNECTOR: P1 & P2: D-SUB 25PIN MALE, SOLDER TYPE, GOLD FLASH CONTACTS.
3. THUMB SCREW TO BE MOLDED.
4. SHIELDING: COPPER-FOIL TAPE COVER PREMOLD AND 360° SOLDER TO CONNECTOR SHELL & CABLE BRAID.
5. ALL HOOD: MOLDED BEIGE(CTG-401) PVC.
6. PACKING: EACH CABLE IN A TNT PRINTED ZIP-LOCK POLY-BAG, BAR CODE LABEL(WHITE BACKGROUND WITH BLACK PRINTED, BAR CODE: 39) TO BE STAMPED ON POLYBAG.

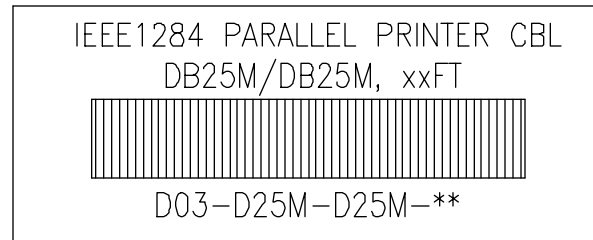
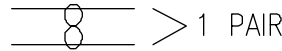

"XX" & "**" SEE CHART 1

DRAWING APPROVED _____		DATE: _____	
SAMPLE APPROVED PER _____		DATE: _____	
<small>PROPRIETARY & CONFIDENTIAL. THIS DOCUMENT MAY NOT BE COPIED, OR DISCLOSED IN WHOLE OR IN PART WITHOUT THE WRITTEN CONSENT OF TNT.</small>			
ϕ \equiv	mm	TITLE PIN OUT	
SCALE	NONE	CUS. NAME	
SHEET	2/2	CUS. P/N	
DIMENSIONAL TOLERANCES UNLESS OTHERWISE NOTED .X \pm .XX \pm		D03-D25M-D25M-XX PART NO.	
<input type="checkbox"/> O		.XXX \pm ANGLES \pm	
<input type="checkbox"/> S		REV. E CUS. REV	
		P9909071-E	
			
		ENG. _____ DATE _____	
		CHECKED _____ DATE _____	
		APPROVED _____ DATE _____	