

Description:

The perfect solution for connecting composite video devices using UTP(Cat5/5e/6) cable, this Composite Video UTP Extender lets you extend signals up to 300ft./100m. R03-EXT-RWY-FP is comprised of two extender units that can be used interchangeably: one is installed near the video signal source, the other to be placed near the desired display, up to an impressive 300ft./100m away. With no software or power adapter required, installation and setup is quick and hassle-free.

Features:

- No software or power adapter required for easy installation.
- Works with UTP (Cat5/5e/6) cable.
- Shell color: White

Applications

- To be used in home or commercial applications as a fast, and cost-effective means of connecting composite video equipment.
- Ideal for classrooms, projectors, convention facilities, and retail displays.

A	INITIAL RELEASE		02/04/10	
REV	DESCRIPTION OF CHANGE			DATE
TOLERANCE		M/M		Tri-Net Technology, Inc. http://www.trinetusa.com
INCHES				
.X	.015	.30		
.XX	.010	.10		
.XXX	.005	.05		SCALE NONE UNIT MM SHEET 1/3 DATE 02/04/10 DWG NO.
DRAWN BY	starl		REV A	
CHECK BY	TITLE			COMPOSITE VIDEO (RWY),One Piece
APPD BY	PART NO.			R03-EXT-RWY-FP-S



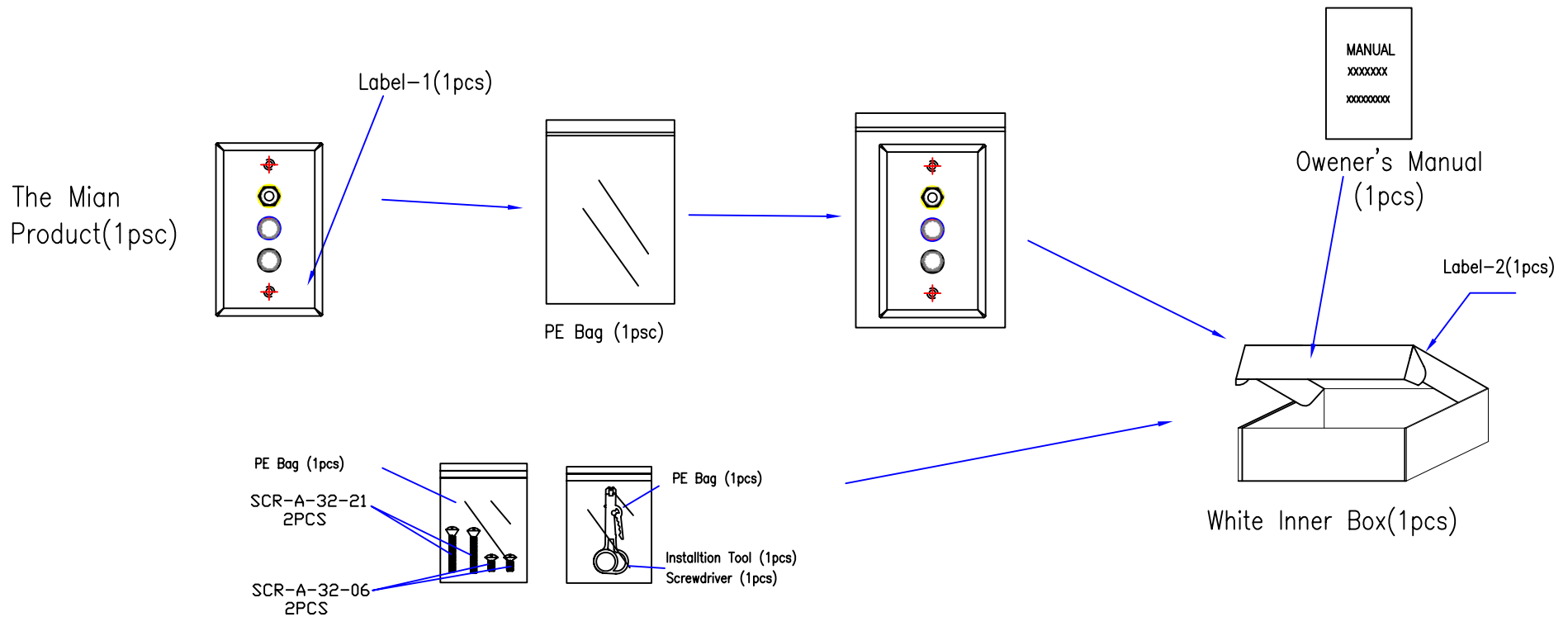

Packaging Details:

- 1) Stick the Label-1 onto the Product's Bottom.
- 2) Put the whole item, the Installation Tool, the enclosed 4pcs of screws (packing with a small PE bag) and owner's manual inside the inner box
- 3) Stick the Label-2 onto this inner box.
- 4) Finally, pack the whole item using pyrocondensation film.
- 5) Inner box size: 125MM (L) X 75MM (W) X 29MM(H)
- 6) Outer carton size: 405MM (L) X 370MM (W) X 185MM (H)
- 7) Put 50pcs of inner boxes into an outer carton.



A		INITIAL RELEASE		02/04/10	
REV		DESCRIPTION OF CHANGE		DATE	
TOLERANCE		M/M		Tri-Net Technology, Inc. http://www.trinetusa.com	
INCHES					
.X	.015	.30			
.XX	.010	.10	SCALE	NONE	REV A
.XXX	.005	.05	UNIT	MM	
DRAWN BY		starl		SHEET 2/3	
CHECK BY				DATE 02/04/10	
APPD BY				DWG NO.	
				TITLE	
				packing-1	
				PART NO.	
				R03-EXT-RWY-FP-S	

Version Label (label-1)

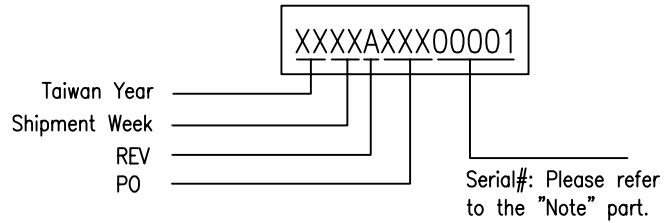

(18x6, Black on White)

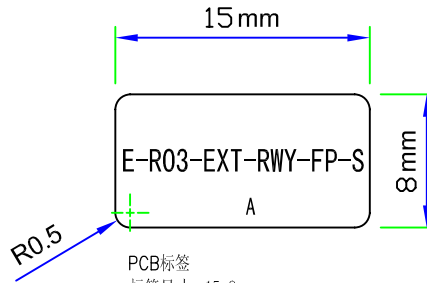

PCB标签
标签尺寸: 15x8mm
标签颜色: 绿色
料号: LAB-E-R03-EXT-RWY-FP-S-GR-A
成品料号: R03-EXT-RWY-FP-S

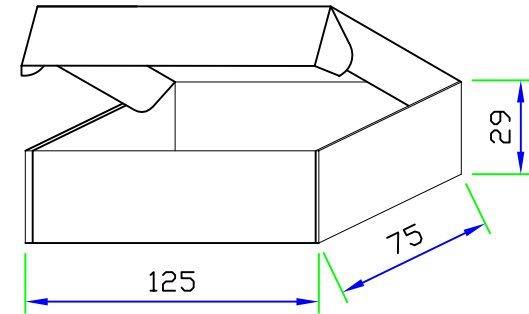

White Inner Box

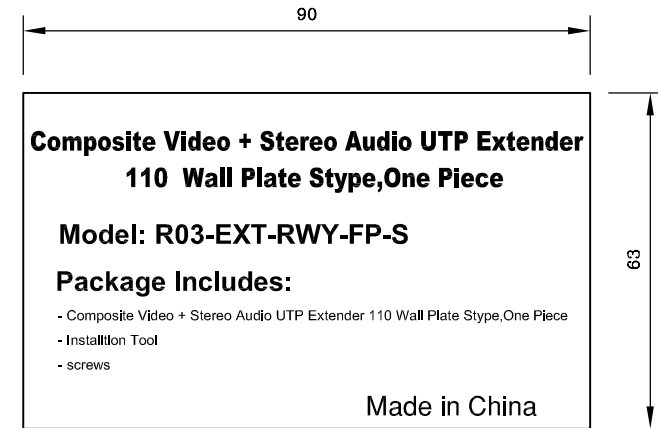

标签-1
标签尺寸: 90x63mm
标签颜色: 黑白

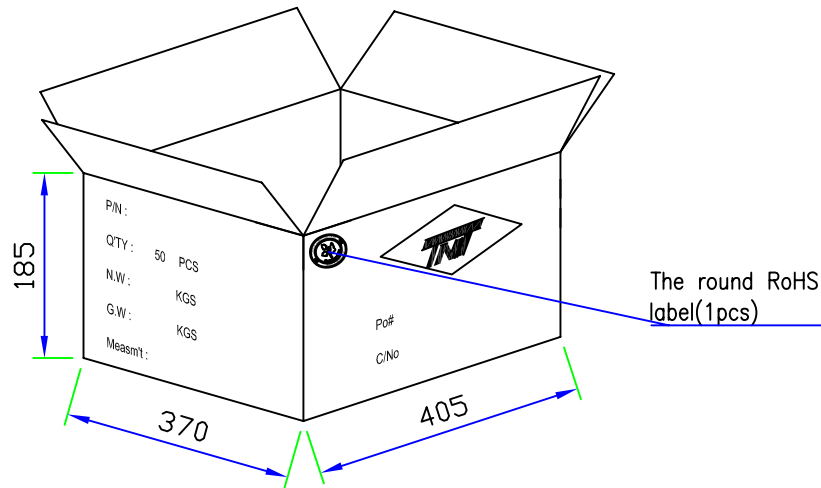

Outer Carton



A	INITIAL RELEASE		02/04/10	
REV	DESCRIPTION OF CHANGE		DATE	
TOLERANCE		M/M		Tri-Net Technology, Inc. http://www.trinetusa.com
INCHES				
.X	.015	.30	SCALE NONE	
.XX	.010	.10	UNIT MM	
.XXX	.005	.05	DATE 02/04/10	REV A
DRAWN BY	starl		SHEET 3/3	DWG NO.
CHECK BY			TITLE packing-2	
APPD BY			PART NO. R03-EXT-RWY-FP-S	