

Description:

The perfect solution for connecting s-video devices using UTP(Cat5/5e/6) cable, this s-Video UTP Extender lets you extend signals up to 300ft./100m. R03-EXT-MD4-FP is comprised of two extender units that can be used interchangeably: one is installed near the video signal source, the other to be placed near the desired display, up to an impressive 300ft./100m away. With no software or power adapter required, installation and setup is quick and hassle-free.

Features:

- No software or power adapter required for easy installation.
- Works with UTP (Cat5/5e/6) cable.
- Shell color: White

Applications

- To be used in home or commercial applications as a fast, and cost-effective means of connecting composite video equipment.
- Ideal for classrooms, projectors, convention facilities, and retail displays.

A	INITIAL RELEASE		12/10/10	
REV	DESCRIPTION OF CHANGE		DATE	
TOLERANCE		M/M		
INCHES		M/M		
.X	.015	.30	TNT Tri-Net Technology, Inc. http://www.trinetusa.com	
.XX	.010	.10	SCALE	NONE
.XXX	.005	.05	UNIT	MM
DRAWN BY		starl	SHEET	1/4
CHECK BY			DATE	12/10/10
APPD BY			DWG NO.	
		TITLE		
		S-VIDEO+STERE AUDIO (S-VIDEO+2RCA)		
		PART NO.		
		R03-EXT-MD4-FP		



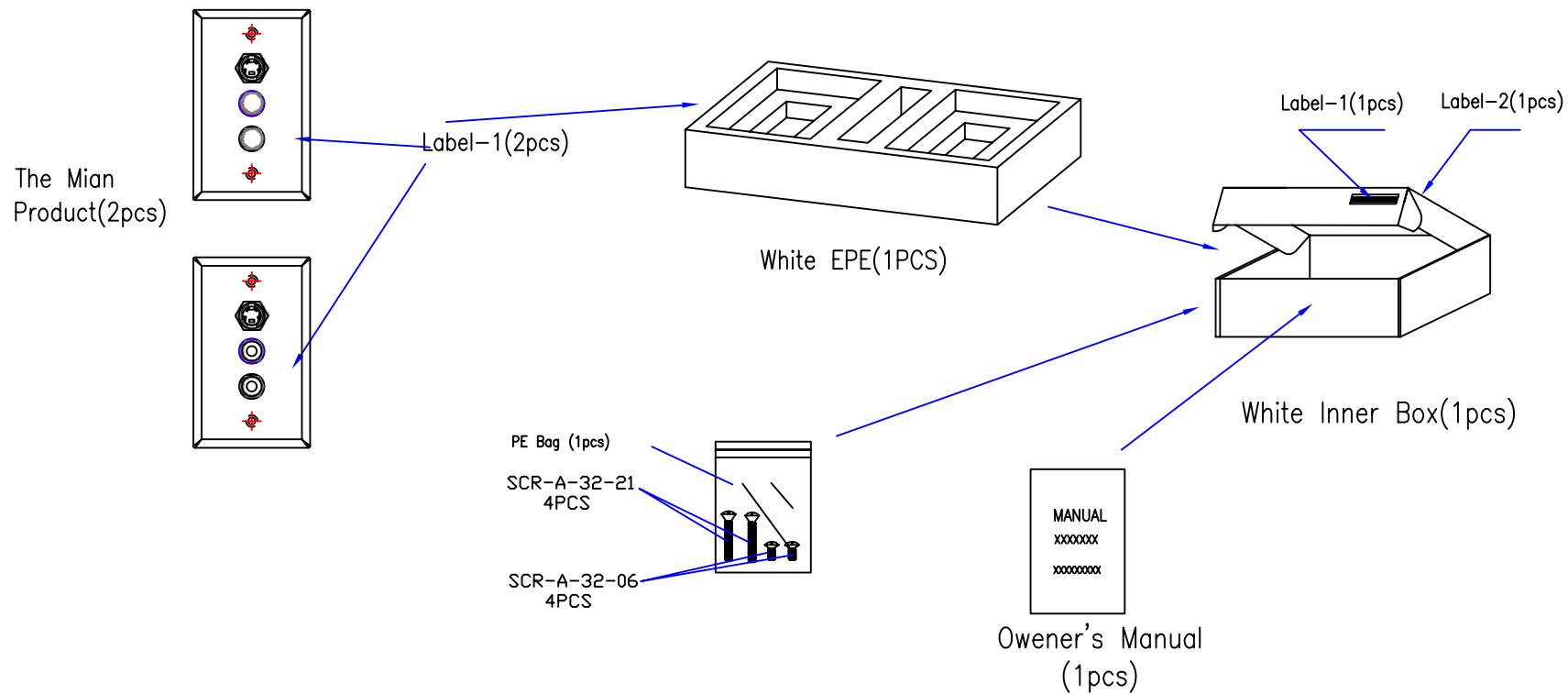

Packaging Details:

- 1) Stick the Label-1 onto the Product's Bottom.
- 2) Put the whole item, the enclosed 4pcs of screws (packing with a small PE bag) and owner's manual inside the inner box
- 3) Stick the Label-2 onto this inner box.
- 4) Inner box size: 201(L)X170(W)X57(H)MM
- 5) Outer carton size: 423(L)X365(W)X325(H)MM
- 6) Put 20pcs of inner boxes into an outer carton.

A		INITIAL RELEASE		12/10/10		
REV	DESCRIPTION OF CHANGE				DATE	
TOLERANCE INCHES		M/M		Tri-Net Technology, Inc. http://www.trinetusa.com		
.X	.015	.30	SCALE			NONE
.XX	.010	.10	UNIT			MM
.XXX	.005	.05	REV A			
DRAWN BY	starl		SHEET	2/4	DWG NO.	
CHECK BY			DATE	12/10/10		
APPD BY			TITLE S-VIDEO+STERE AUDIO (S-VIDEO+2RCA)			
			PART NO. R03-EXT-MD4-FP			



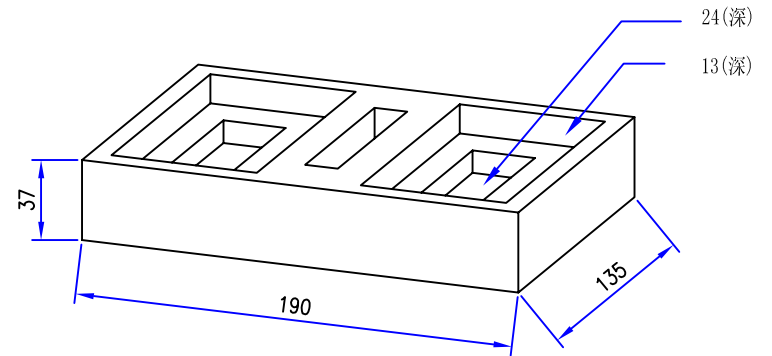
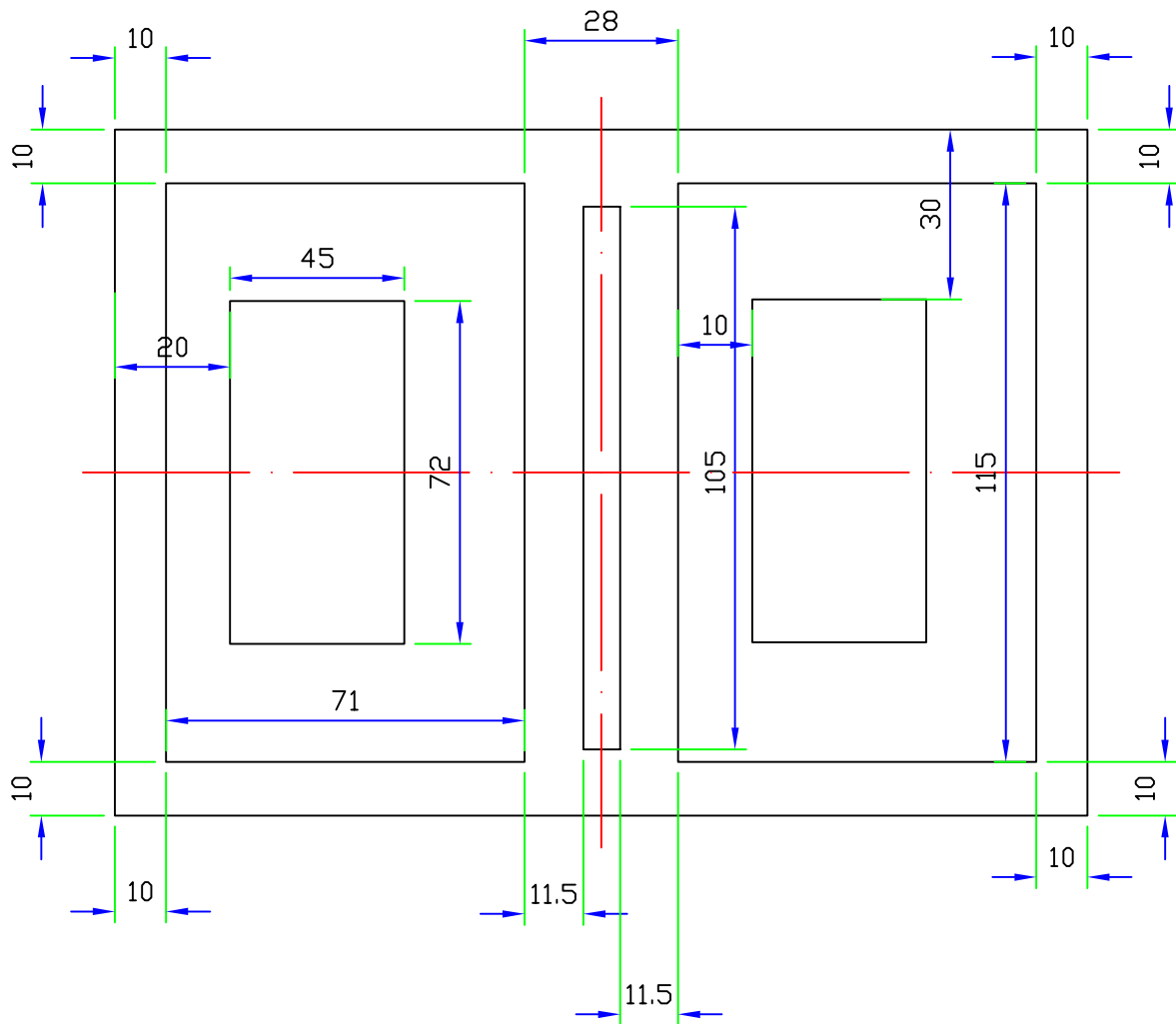

EPE-190-135-37

A	INITIAL RELEASE		12/10/10	
REV	DESCRIPTION OF CHANGE		DATE	
TOLERANCE		M/M		
INCHES				
.X	.015	.30	TNT Tri-Net Technology, Inc. http://www.trinetusa.com	
.XX	.010	.10	SCALE	NONE
.XXX	.005	.05	UNIT	MM
DRAWN BY		starl	SHEET	3/4
CHECK BY			DATE	12/10/10
APPD BY			DWG NO.	REV A
		TITLE		
		S-VIDEO+STEREO AUDIO (S-VIDEO+2RCA)		
		PART NO.		
		R03-EXT-MD4-FP		



QP-012-02-G

Version Label

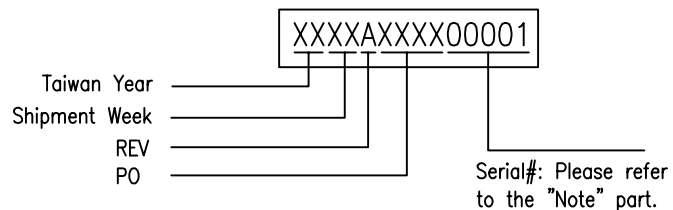

Label-1
(18x6, Black on White)

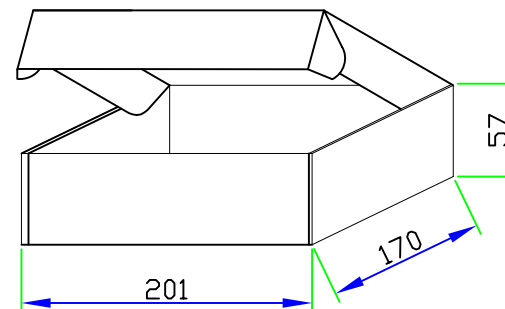

White Inner Box

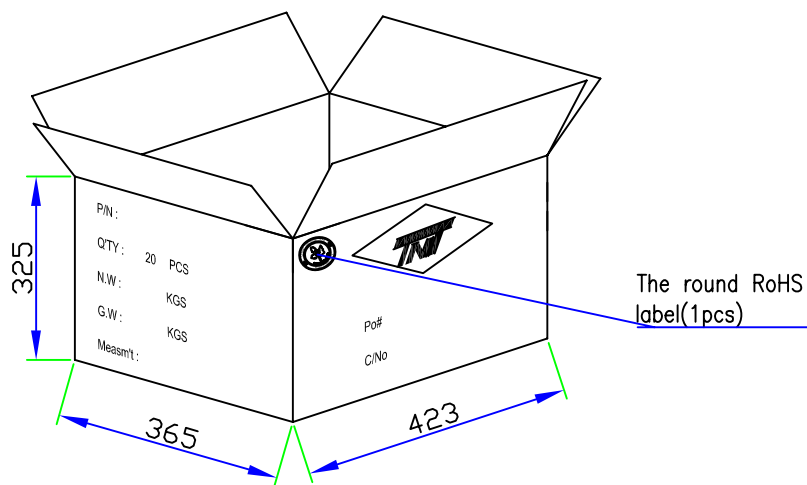

Outer Carton

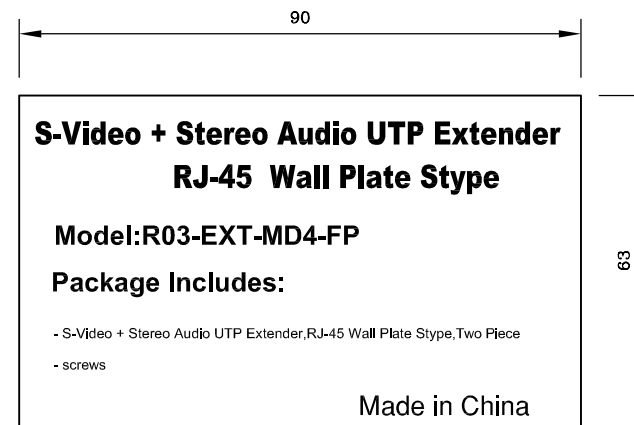

Label-2
标签尺寸: 90x63mm
标签颜色: 黑白

A	INITIAL RELEASE		12/10/10		
REV	DESCRIPTION OF CHANGE		DATE		
TOLERANCE		M/M		Tri-Net Technology, Inc. http://www.trinetusa.com	
.X	.015	.30	SCALE		NONE
.XX	.010	.10	UNIT		MM
.XXX	.005	.05	DATE	12/10/10	REV A
DRAWN BY	starl		SHEET	4/4	DWG NO.
CHECK BY			DATE	12/10/10	
APPD BY			TITLE	S-VIDEO+STERE AUDIO (S-VIDEO+2RCA)	
			PART NO.	R03-EXT-MD4-FP	

