

### Description:

The perfect solution for connecting composite video devices using UTP(Cat5/5e/6) cable, this Composite Video UTP Extender lets you extend signals up to 300ft./100m. With no software or power adapter required, installation and setup is quick and hassle-free.

### Features:

- No software or power adapter required for easy installation.
- Works with UTP (Cat5/5e/6) cable.
- Shell color: White

### Applications

- To be used in home or commercial applications as a fast, and cost-effective means of connecting composite video equipment.
- Ideal for classrooms, projectors, convention facilities, and retail displays.

A	INITIAL RELEASE		12/10/10			
REV	DESCRIPTION OF CHANGE		DATE			
TOLERANCE		M/M		<b>Tri-Net Technology, Inc.</b> <a href="http://www.trinetusa.com">http://www.trinetusa.com</a>		
.X	.015	.30	SCALE		NONE	
.XX	.010	.10	UNIT		MM	
.XXX	.005	.05	SHEET	1/4	DWG NO.	
DRAWN BY	starl		DATE	12/10/10	REV	A
CHECK BY			TITLE			
APPD BY			PART NO.			
			R03-EXT-MD4-FP-S			



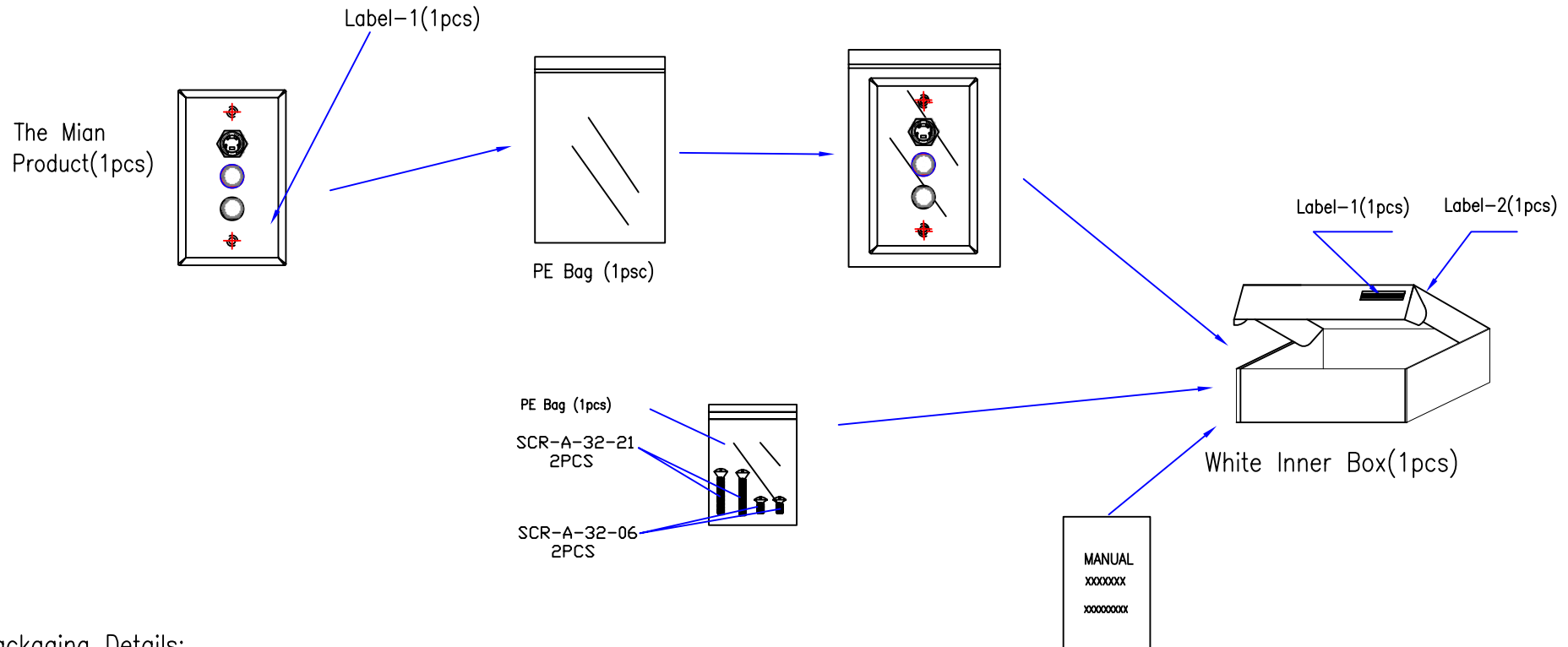

**Packaging Details:**

- 1) Stick the Label-1 onto the Product's Bottom.
- 2) Put the whole item, the enclosed 4pcs of screws (packing with a small PE bag) and owner's manual inside the inner box
- 3) Stick the Label-2 onto this inner box.
- 4) Finally, pack the whole item using pyrocondensation film.
- 5) Inner box size: 125MM (L) X 75MM (W) X 57MM(H)
- 6) Outer carton size: 405MM (L) X 370MM (W) X 185MM (H)
- 7) Put 30pcs of inner boxes into an outer carton.



A		INITIAL RELEASE		12/10/10	
REV		DESCRIPTION OF CHANGE		DATE	
TOLERANCE INCHES		M/M		TNT Tri-Net Technology, Inc. http://www.trinetusa.com	
.X	.015	.30	SCALE	NONE	REV A
.XX	.010	.10	UNIT	MM	
.XXX	.005	.05	SHEET	2/4	
DRAWN BY		starl		DATE	12/10/10
CHECK BY				TITLE S-VIDEO+STEREO AUDIO (S-VIDEO+2RCA)	
APPD BY				PART NO. R03-EXT-MD4-FP-S	

Version Label

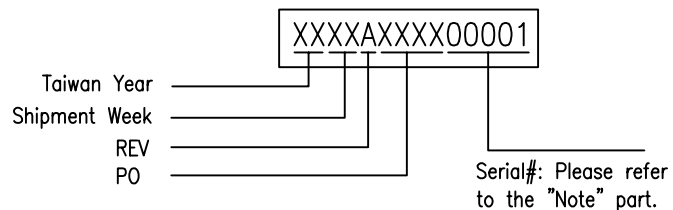

Label-1  
(18x6, Black on White)

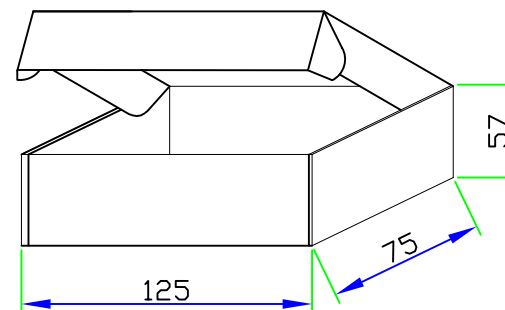

White Inner Box

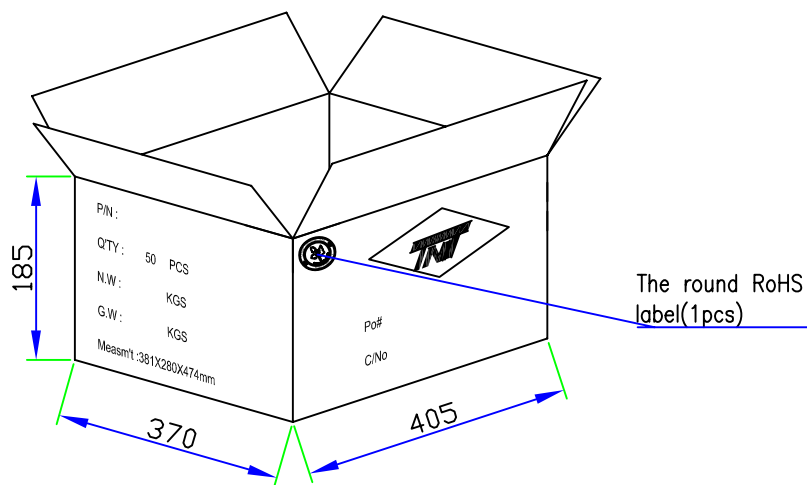

Outer Carton

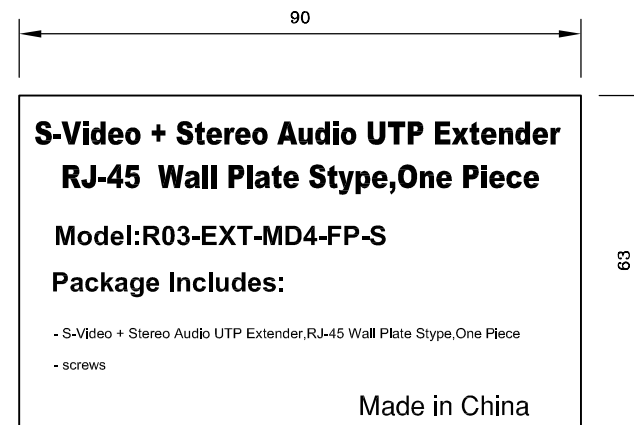

Label-2  
标签尺寸: 90x63mm  
标签颜色: 黑白

A	INITIAL RELEASE		12/10/10		
REV	DESCRIPTION OF CHANGE		DATE		
TOLERANCE INCHES		M/M		Tri-Net Technology, Inc. <a href="http://www.trinetusa.com">http://www.trinetusa.com</a>	
.X	.015	.30	SCALE		NONE
.XX	.010	.10	UNIT		MM
.XXX	.005	.05	DATE	12/10/10	REV A
DRAWN BY	starl		SHEET	4/4	DWG NO.
CHECK BY			DATE	12/10/10	
APPD BY			TITLE	S-VIDEO+STERE AUDIO (S-VIDEO+2RCA)	
			PART NO.	R03-EXT-MD4-FP-S	

