

CUSTOMER: TNTUSA

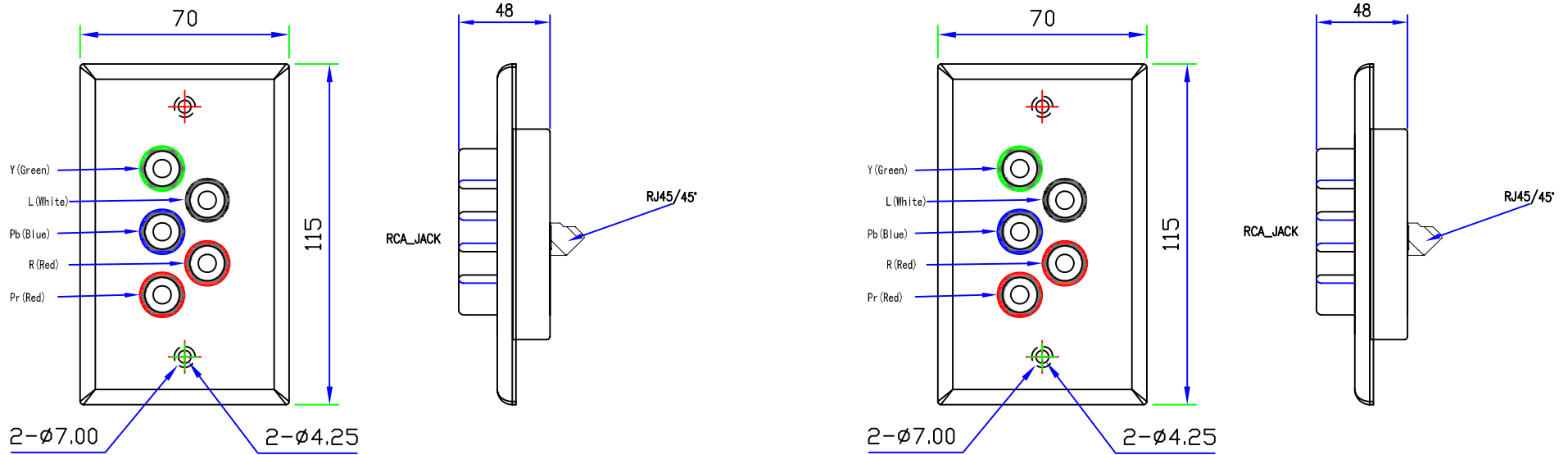

Description:

The perfect solution for connecting component video devices using UTP(Cat5/5e/6) cable, this Component Video (YPbPr) UTP Extender lets you extend signals up to 300ft./100m. R03-EXT-5RCA-JP is comprised of two extender units that can be used interchangeably: one is installed near the video signal source, the other to be placed near the desired display, up to an impressive 300ft./100m away. With no software or power adapter required, installation and setup is quick and hassle-free.

Features:

- No software or power adapter required for easy installation.
- Support up HDTV .(480p/720p/1080i)
- Works with UTP (Cat5/5e/6) cable.
- Shell color: White

Applications

- To be used in home or commercial applications as a fast, and cost-effective means of connecting composite video equipment.
- Ideal for classrooms, projectors, convention facilities, and retail displays.



A	INITIAL RELEASE		12/10/10	
REV	DESCRIPTION OF CHANGE		DATE	
TOLERANCE INCHES		M/M	TNT Tri-Net Technology, Inc. http://www.trinetusa.com	
.X	.015	.30	SCALE	NONE
.XX	.010	.10	UNIT	MM
.XXX	.005	.05	SHEET	1/4
DRAWN BY		starl	DATE	12/10/10
CHECK BY			TITLE COMPONENT VIDEO+STEREO AUDIO RJ-45 WALL PLATE STYPE (5RCA)	
APPD BY			PART NO. R03-EXT-5RCA-JP	

CUSTOMER: TNTUSA

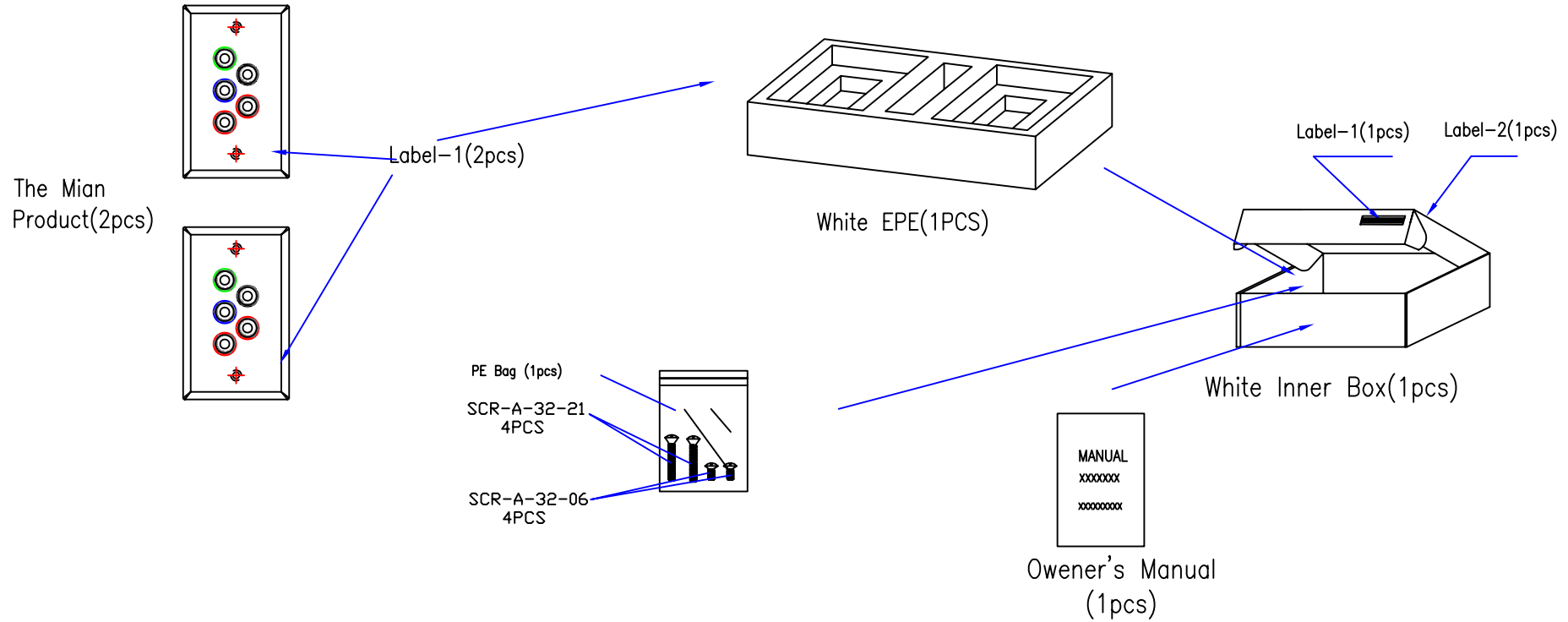

Packaging Details:

- 1) Stick the Label-1 onto the Product's Bottom.
- 2) Put the whole item, the enclosed 4pcs of screws (packing with a small PE bag) and owner's manual inside the inner box
- 3) Stick the Label-2 onto this inner box.
- 4) Inner box size: 201(L)X170(W)X57(H)MM
- 5) Outer carton size: 423(L)X365(W)X325(H)MM
- 6) Put 20pcs of inner boxes into an outer carton.

A	INITIAL RELEASE		12/10/10	
REV	DESCRIPTION OF CHANGE			DATE
TOLERANCE INCHES		M/M		Tri-Net Technology, Inc. http://www.trinetusa.com
.X	.015	.30	SCALE NONE	
.XX	.010	.10	UNIT MM	
.XXX	.005	.05	DATE 12/10/10	REV A
DRAWN BY	starl		SHEET 2/4	DWG NO.
CHECK BY			DATE 12/10/10	
APPD BY			TITLE COMPONENT VIDEO+STEREO AUDIO RJ-45 WALL PLATE STYPE (SRCA)	
			PART NO. R03-EXT-5RCA-JP	



CUSTOMER: TNTUSA

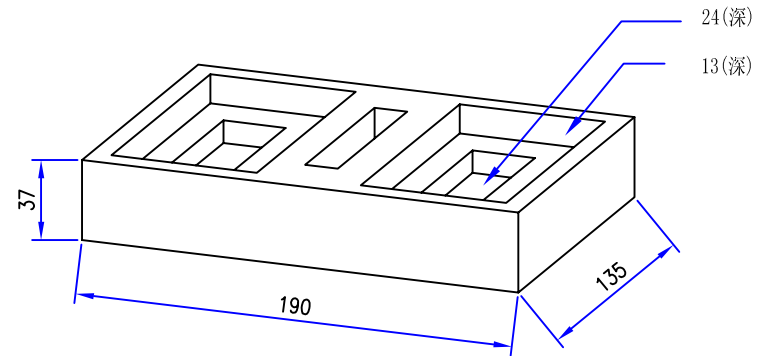
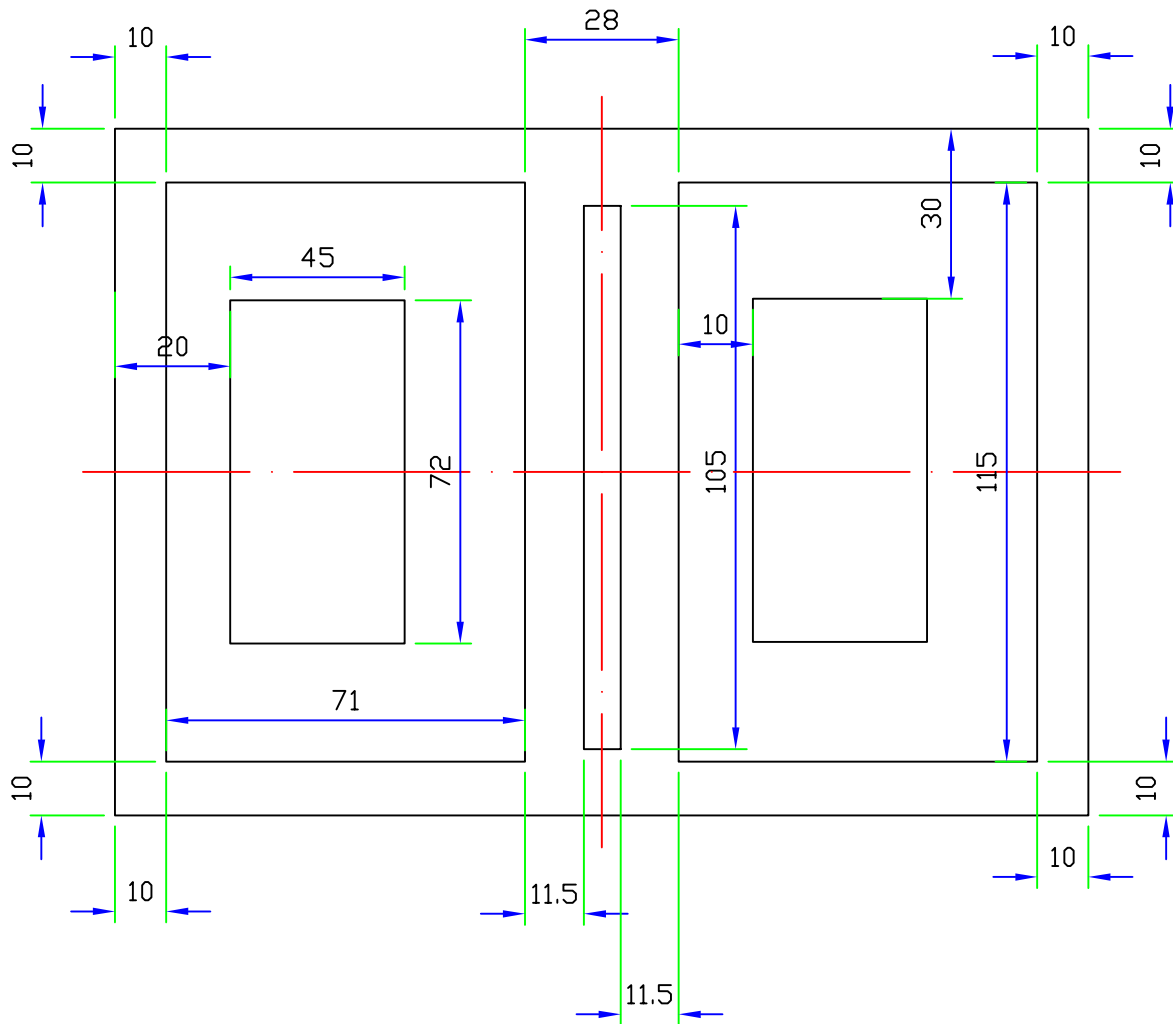

EPE-190-135-37

A	INITIAL RELEASE		12/10/10	
REV	DESCRIPTION OF CHANGE			DATE
TOLERANCE		M/M		
INCHES				
.X	.015	.30	TNT Tri-Net Technology, Inc. http://www.trinetusa.com	
.XX	.010	.10	SCALE	NONE
.XXX	.005	.05	UNIT	MM
DRAWN BY		starl		REV A
CHECK BY		DATE		SHEET 3/4 DWG NO.
APPD BY		TITLE		DATE 12/10/10
		COMPONENT VIDEO+STEREO AUDIO RJ-45 WALL PLATE STYPE (SRCA)		
		PART NO.		R03-EXT-5RCA-JP



QP-012-02-G

CUSTOMER: TNTUSA

Version Label

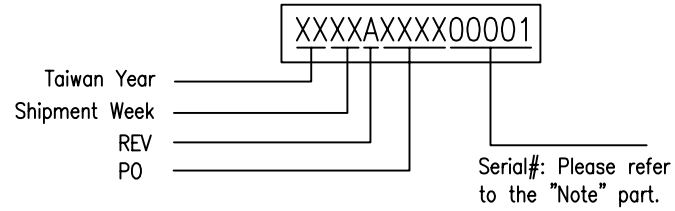

Label-1
(18x6, Black on White)

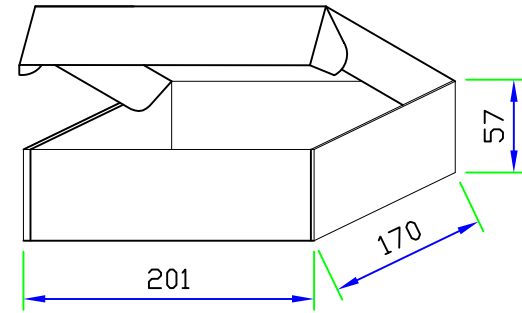

White Inner Box

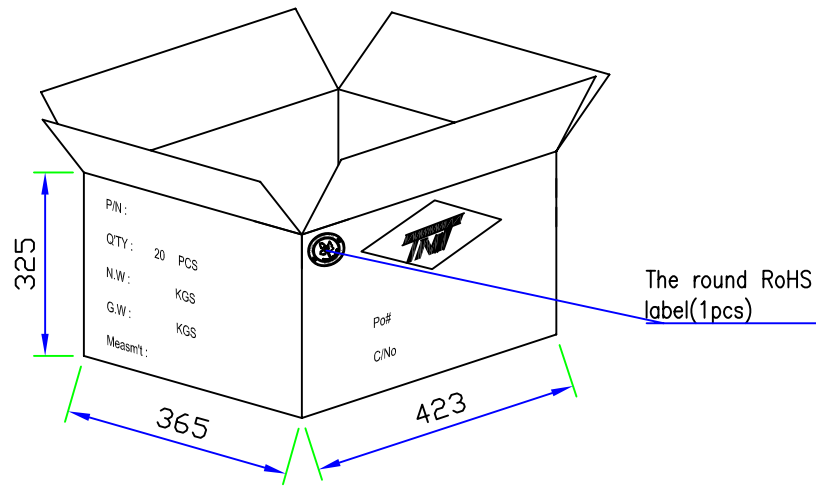

Outer Carton

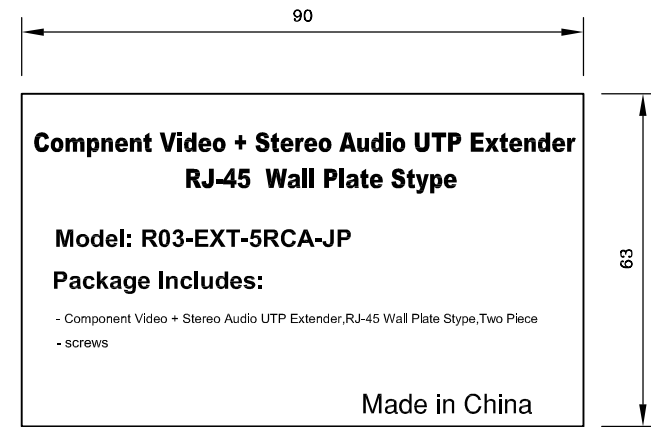

Label-2
标签尺寸: 90x63mm
标签颜色: 黑白

A	INITIAL RELEASE		12/10/10		
REV	DESCRIPTION OF CHANGE		DATE		
TOLERANCE INCHES		M/M		Tri-Net Technology, Inc. http://www.trinetusa.com	
.X	.015	.30	SCALE		NONE
.XX	.010	.10	UNIT		MM
.XXX	.005	.05	DATE	12/10/10	REV A
DRAWN BY	starl		SHEET	4/4	DWG NO.
CHECK BY			DATE	12/10/10	
APPD BY			TITLE	COMPONENT VIDEO+STEREO AUDIO RJ-45 WALL PLATE STYLE (5RCA)	
			PART NO.	R03-EXT-5RCA-JP	

