

Description:

The perfect solution for connecting component video devices using UTP (Cat5/5e/6) cable, this Component Video (YPbPr) UTP Extender lets you extend signals up to 300ft./100m. R03-EXT-5RCA-FP is comprised of two extender units that can be used interchangeably: one is installed near the video signal source, the other to be placed near the desired display, up to an impressive 300ft./100m away. With no software or power adapter required, installation and setup is quick and hassle-free.

Features:

- No software or power adapter required for easy installation.
- Support up to HDTV (480p/720p/1080i)
- Works with UTP (Cat5/5e/6) cable.
- Shell color: White

Applications

- To be used in home or commercial applications as a fast, and cost-effective means of connecting composite video equipment.
- Ideal for classrooms, projectors, convention facilities, and retail displays.

A	INITIAL RELEASE		02/02/10		
REV	DESCRIPTION OF CHANGE		DATE		
TOLERANCE		M/M		Tri-Net Technology, Inc. http://www.trinetusa.com	
.X	.015	.30	SCALE		NONE
.XX	.010	.10	UNIT		MM
.XXX	.005	.05	SHEET	1/4	REV A
DRAWN BY	starl		DATE	02/02/10	DWG NO.
CHECK BY			TITLE COMPONENT VIDEO+STEREO AUDIO 110 WALL PLATE STYPE (5RCA)		
APPD BY			PART NO. R03-EXT-5RCA-FP		



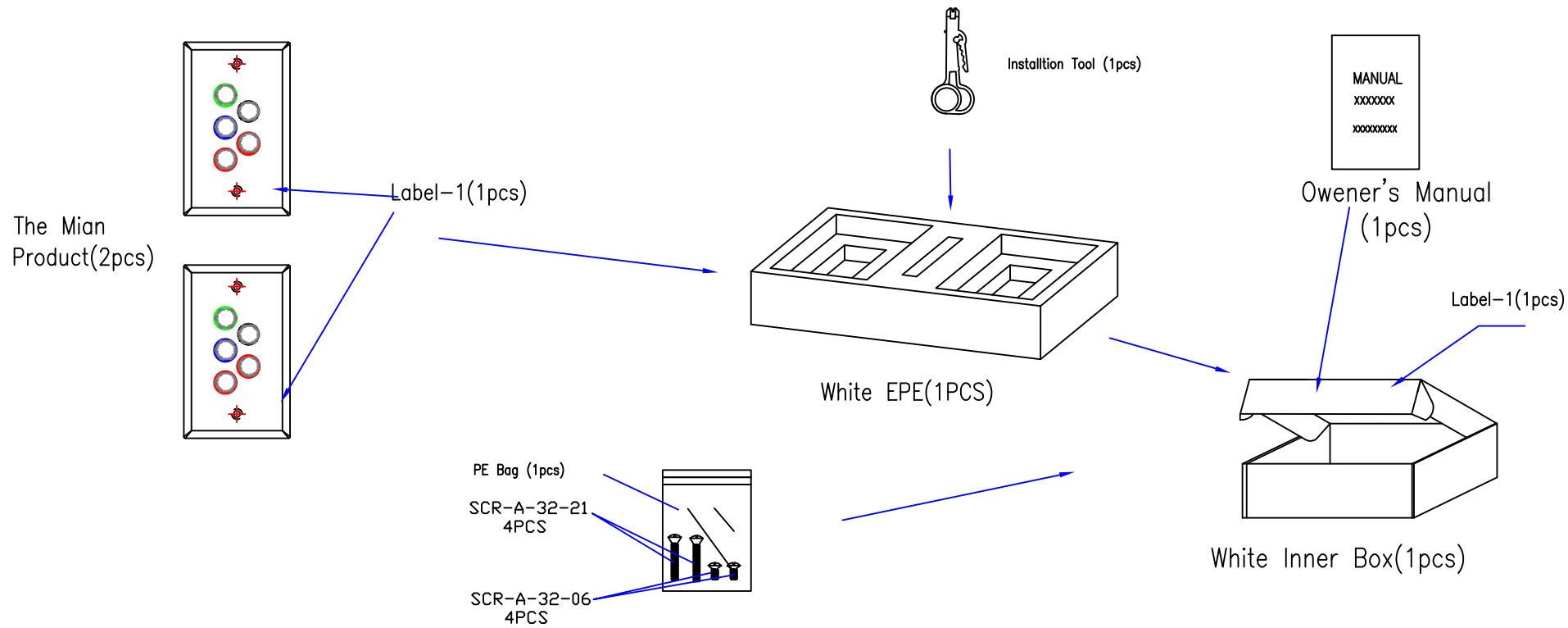

Packaging Details:

- 1) Stick the Label-1 onto the Product's Bottom.
- 2) Put the whole item, the Installation Tool, the enclosed 4pcs of screws (packing with a small PE bag) and owner's manual inside the inner box
- 3) Stick the Label-2 onto this inner box.
- 4) Inner box size: 200(L)X140(W)X42(H)MM
- 5) Outer carton size: 412(L)X292(W)X230(H)MM
- 6) Put 20pcs of inner boxes into an outer carton.

A	INITIAL RELEASE		02/02/10	
REV	DESCRIPTION OF CHANGE		DATE	
TOLERANCE		M/M		
INCHES		M/M		
.X	.015	.30	TNT Tri-Net Technology, Inc. http://www.trinetusa.com	
.XX	.010	.10	SCALE	NONE
.XXX	.005	.05	UNIT	MM
DRAWN BY		starl	SHEET	2/4
CHECK BY			DATE	02/02/10
APPD BY			DWG NO.	
		TITLE		
		COMPONENT VIDEO+STEREO AUDIO 110 WALL PLATE STYPE (5RCA)		
		PART NO.		
		R03-EXT-5RCA-FP		



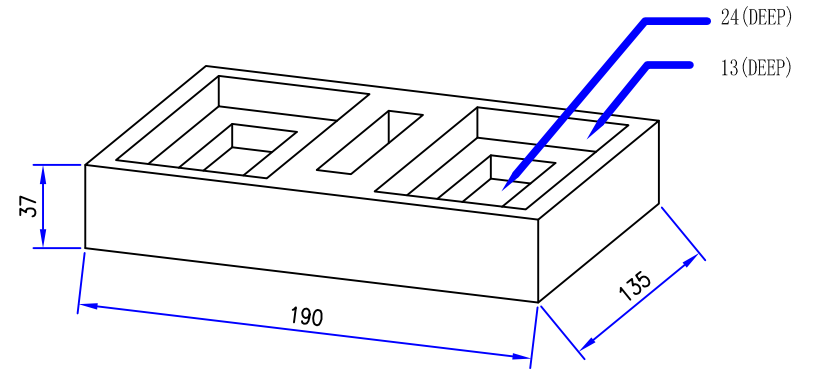
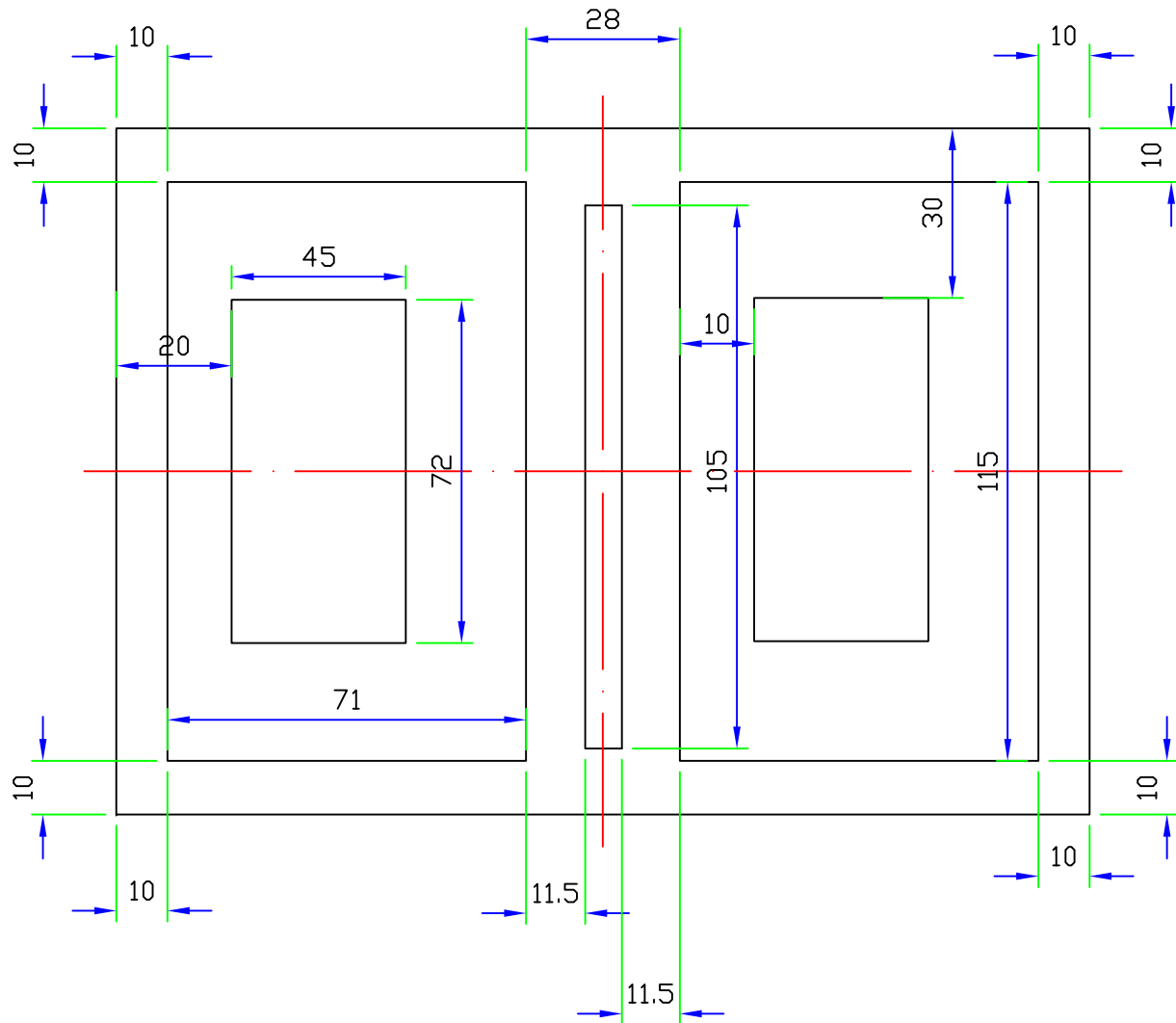

EPE-190-135-37

A	INITIAL RELEASE		02/02/10	
REV	DESCRIPTION OF CHANGE		DATE	
TOLERANCE INCHES		M/M	Tri-Net Technology, Inc. http://www.trinetusa.com	
.X	.015	.30	SCALE	NONE
.XX	.010	.10	UNIT	MM
.XXX	.005	.05	DATE	02/02/10
DRAWN BY	star1		SHEET	3/4
CHECK BY			DATE	02/02/10
APPD BY			DWG NO.	
			TITLE	COMPONENT VIDEO+STEREO AUDIO 110 WALL PLATE STYPE (5RCA)
			PART NO.	R03-EXT-5RCA-FP



Version Label (Label-1)

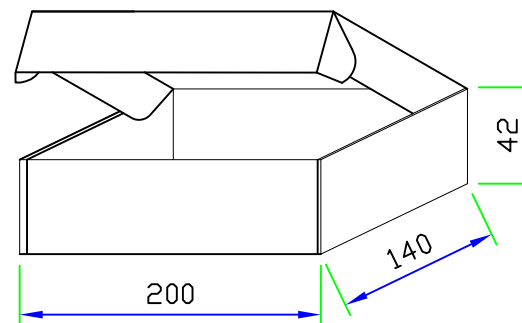
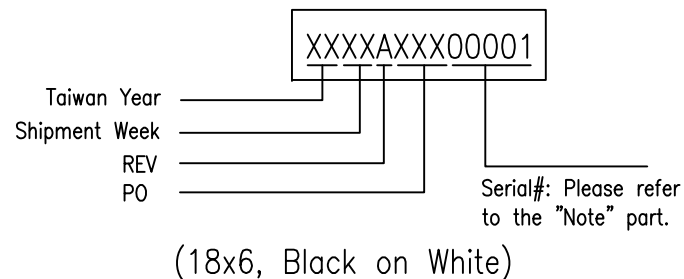

White Inner Box

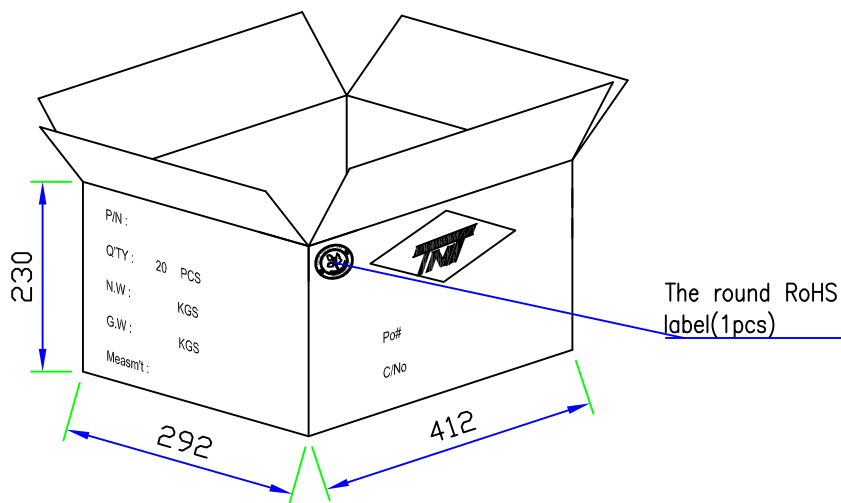

Outer Carton

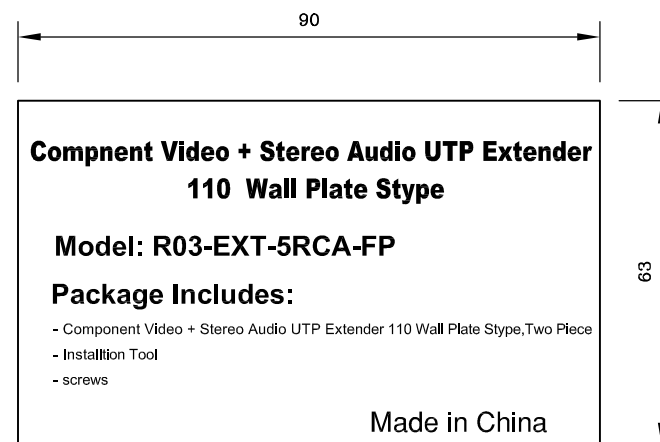

标签-1
标签尺寸: 90x63mm
标签颜色: 黑白

A	INITIAL RELEASE		02/02/10	
REV	DESCRIPTION OF CHANGE		DATE	
TOLERANCE		M/M		Tri-Net Technology, Inc. http://www.trinetusa.com
INCHES				
.X	.015	.30		
.XX	.010	.10	SCALE NONE	REV A
.XXX	.005	.05	UNIT MM	
DRAWN BY	starl		SHEET 4/4	DWG NO.
CHECK BY			DATE 02/02/10	TITLE PACKING
APPD BY			PART NO.	R03-EXT-5RCA-FP

