

Description:

The perfect solution for connecting component video devices using UTP(Cat5/5e/6) cable, this Component Video (YPbPr) UTP Extender lets you extend signals up to 300ft./100m. R03-EXT-5RCA-FP-S is comprised of two extender units that can be used interchangeably: one is installed near the video signal source, the other to be placed near the desired display, up to an impressive 300ft./100m away. With no software or power adapter required, installation and setup is quick and hassle-free.

Features:

- No software or power adapter required for easy installation.
- Support up HDTV (.480p/720p/1080i)
- Works with UTP (Cat5/5e/6) cable.
- Shell color: White

Applications

- To be used in home or commercial applications as a fast, and cost-effective means of connecting composite video equipment.
- Ideal for classrooms, projectors, convention facilities, and retail displays.



A	INITIAL RELEASE		02/01/10	
REV	DESCRIPTION OF CHANGE		DATE	
TOLERANCE		TNT Tri-Net Technology, Inc. http://www.trinetusa.com		
INCHES		M/M	SCALE	NONE
.X	.015	.30	UNIT	MM
.XX	.010	.10	SHEET	1/3
.XXX	.005	.05	DATE	02/01/10
DRAWN BY	starl		DWG NO.	
CHECK BY			TITLE	COMPONENT VIDEO+STEREO AUDIO 110 WALL PLATE STYPE,ONE PIECE(SRCA)
APPD BY			PART NO.	R03-EXT-5RCA-FP-S

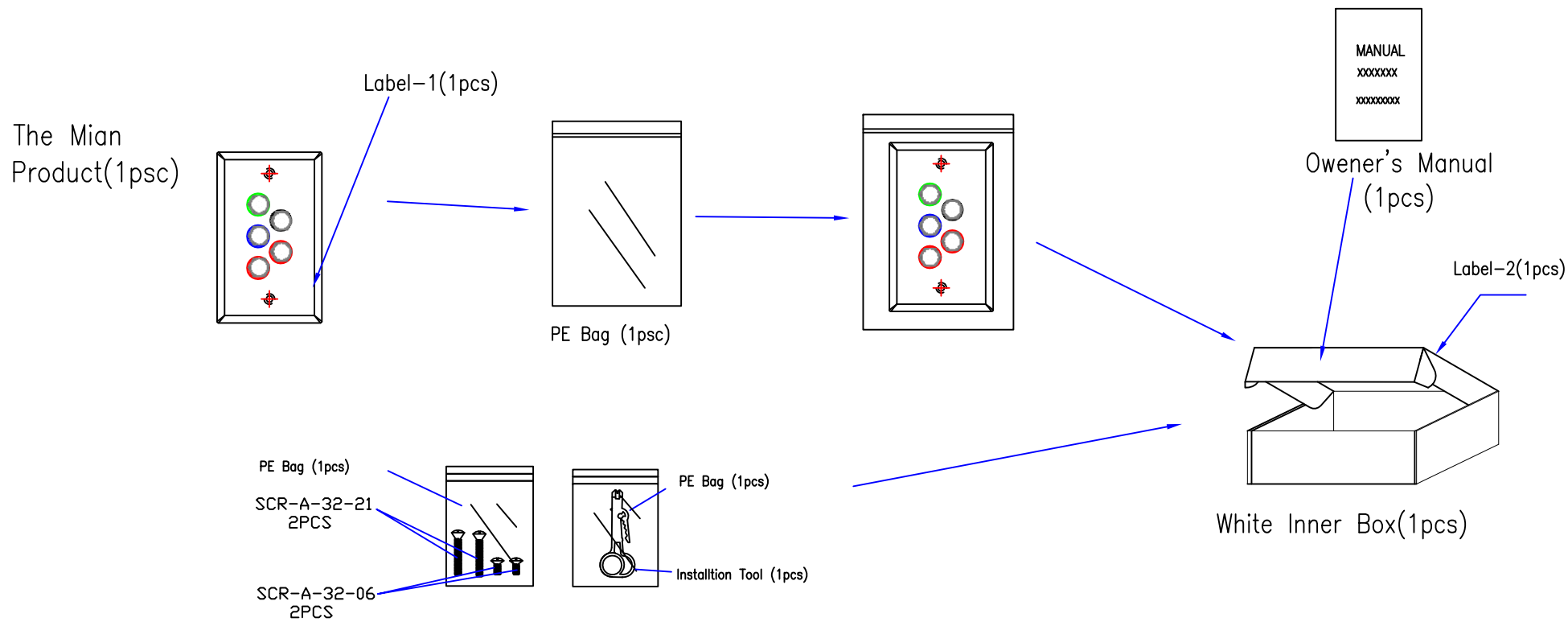

Packaging Details:

- 1) Stick the Label-1 onto the Product's Bottom.
- 2) Put the whole item, the Installation Tool, the enclosed 4pcs of screws (packing with a small PE bag) and owner's manual inside the inner box
- 3) Stick the Label-2 onto this inner box.
- 4) Finally, pack the whole item using pyrocondensation film.
- 5) Inner box size: 125MM (L) X 75MM (W) X 29MM(H)
- 6) Outer carton size: 405MM (L) X 370MM (W) X 185MM (H)

A	INITIAL RELEASE		02/01/10		
REV	DESCRIPTION OF CHANGE		DATE		
TOLERANCE		M/M		Tri-Net Technology, Inc. http://www.trinetusa.com	
.X	.015	.30	SCALE		NONE
.XX	.010	.10	UNIT		MM
.XXX	.005	.05	SHEET	2/3	REV A
DRAWN BY	starl		DATE	02/01/10	DWG NO.
CHECK BY			TITLE packing-1		
APPD BY			PART NO. R03-EXT-5RCA-FP-S		



Version Label

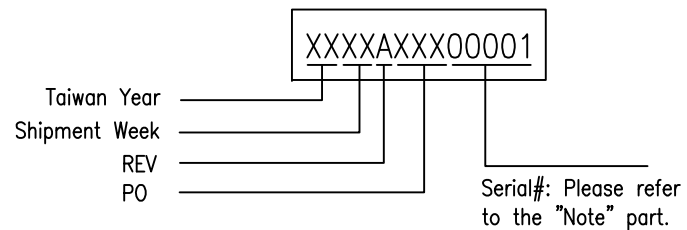

(18x6, Black on White)

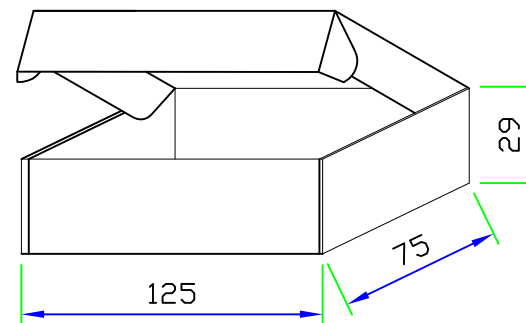

White Inner Box

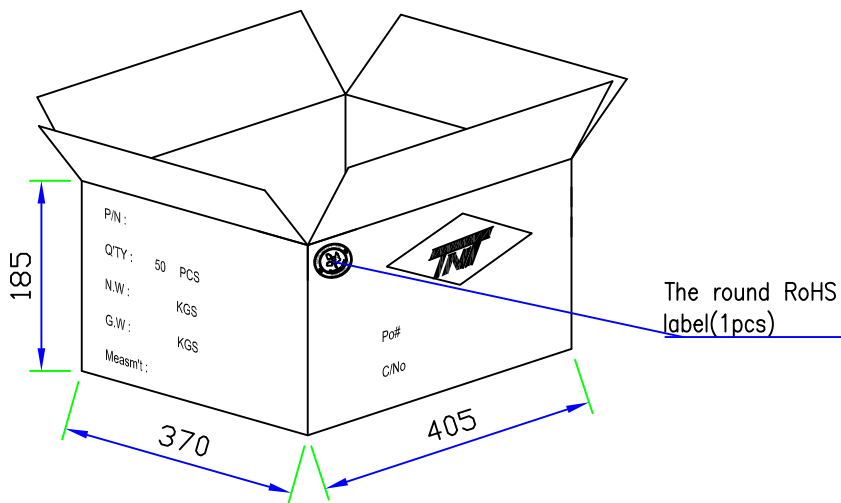

Outer Carton

90

**Component Video + Stereo Audio UTP Extender
110 Wall Plate Style,One Piece**

Model: R03-EXT-5RCA-FP-S

Package Includes:

- Component Video + Stereo Audio UTP Extender 110 Wall Plate Style,One Piece
- Installation Tool
- screws

63

Made in China

LABEL-2 90*63MM

A	INITIAL RELEASE		02/01/10	
REV	DESCRIPTION OF CHANGE		DATE	
TOLERANCE			Tri-Net Technology, Inc.	
INCHES			M/M	
.X	.015	.30	SCALE	NONE
.XX	.010	.10	UNIT	MM
.XXX	.005	.05	SHEET	3/3
			DATE	02/01/10
DRAWN BY			starl	
CHECK BY			TITLE	
APPD BY			packing-2	
			PART NO.	
			R03-EXT-5RCA-FP-S	

