

**Description:**

The perfect solution for connecting component video devices using UTP(Cat5/5e/6) cable, this Component Video (YPbPr) UTP Extender lets you extend signals up to 300ft./100m. With no software or power adapter required, installation and setup is quick and hassle-free.

**Features:**

- No software or power adapter required for easy installation.
- Support up HDTV ,(480p/720p/1080i)
- Works with UTP (Cat5/5e/6) cable.
- Shell color: White

**Applications**

- To be used in home or commercial applications as a fast, and cost-effective means of connecting composite video equipment.
- Ideal for classrooms, projectors, convention facilities, and retail displays.

A		INITIAL RELEASE		12/10/09	
REV	DESCRIPTION OF CHANGE			DATE	
TOLERANCE		M/M		Tri-Net Technology, Inc. <a href="http://www.trinetusa.com">http://www.trinetusa.com</a>	
INCHES					
.X	.015	.30			
.XX	.010	.10		SCALE	NONE
.XXX	.005	.05		UNIT	MM
DRAWN BY		starl		SHEET	1/3
CHECK BY				DATE	12/10/09
APPD BY				DWG NO.	
TITLE				REV A	
COMPONENT VIDEO+DIGITAL AUDIO (4RCA),ONE PIECE				PART NO.	
				R03-EXT-4RCA-FP-S	



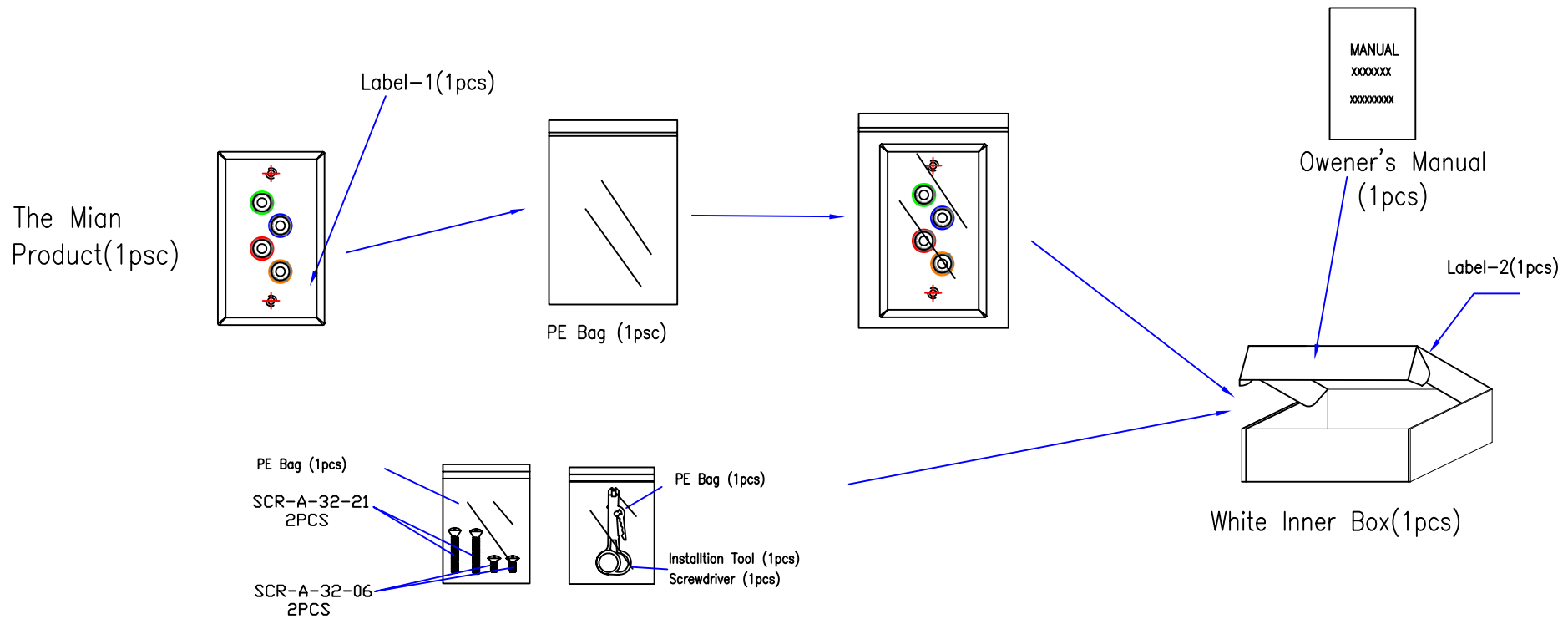

**Packaging Details:**

- 1) Stick the Label-1 onto the Product's Bottom.
- 2) Put the whole item, the Installation Tool, the enclosed 4pcs of screws (packing with a small PE bag) and owner's manual inside the inner box
- 3) Stick the Label-2 onto this inner box.
- 4) Finally, pack the whole item using pyrocondensation film.
- 5) Inner box size: 125MM (L) X 75MM (W) X 29MM(H)
- 6) Outer carton size: 405MM (L) X 370MM (W) X 185MM (H)
- 7) Put 60pcs of inner boxes into an outer carton. Need to put 4pcs of Overpack Labels onto the main/side marks portion of the outer carton.



A	INITIAL RELEASE		01/18/10	
REV	DESCRIPTION OF CHANGE			DATE
TOLERANCE INCHES		M/M	<b>TNT</b> Tri-Net Technology, Inc. <a href="http://www.trinetusa.com">http://www.trinetusa.com</a>	
.X	.015	.30	SCALE	NONE
.XX	.010	.10	UNIT	MM
.XXX	.005	.05	REV A	
DRAWN BY	starl		SHEET	2/3
CHECK BY			DATE	01/18/10
APPD BY			TITLE	
			COMPONENT VIDEO+DIGITAL AUDIO (4RCA), ONE PIECE	
			PART NO. R03-EXT-4RCA-FP-S	

Version Label (Label-1)

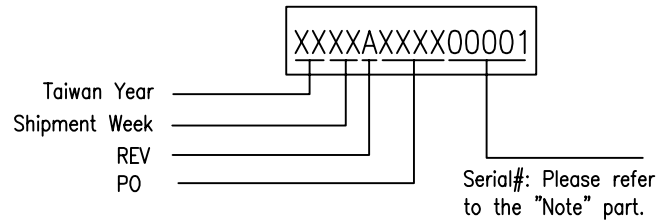

(18x6, Black on White)

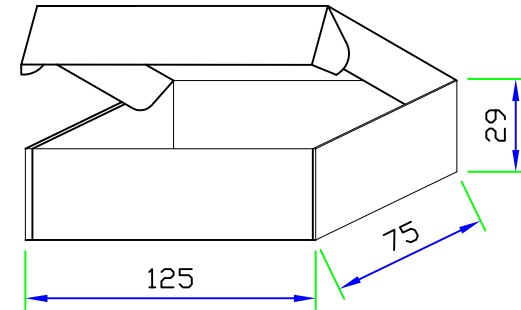

White Inner Box

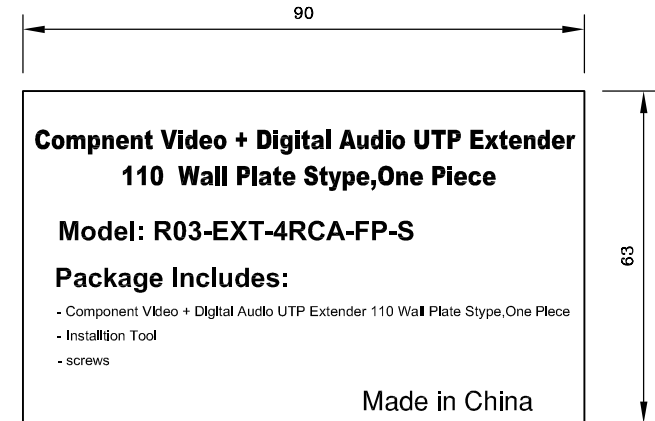

标签-2

标签尺寸: 90x63mm

标签颜色: 黑白

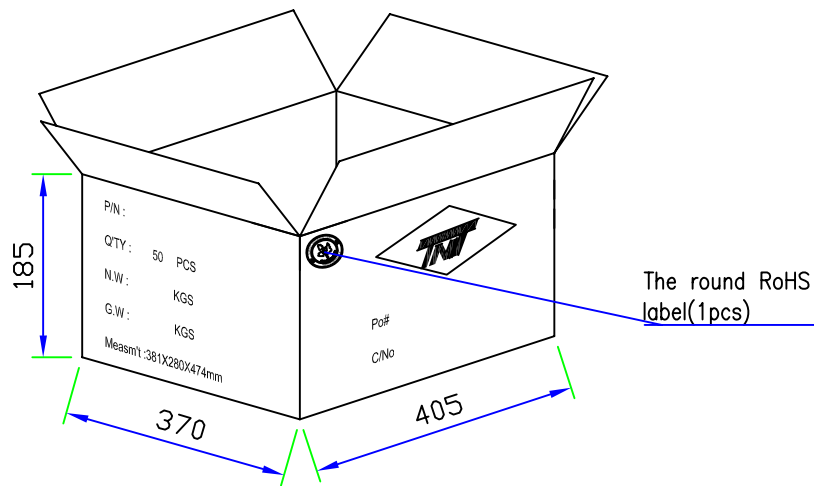

The round RoHS label(1pcs)

Outer Carton



A	INITIAL RELEASE		01/18/10	
REV	DESCRIPTION OF CHANGE		DATE	
TOLERANCE INCHES		M/M	TNT Tri-Net Technology, Inc. http://www.trinetusa.com	
.X	.015	.30	SCALE	NONE
.XX	.010	.10	UNIT	MM
.XXX	.005	.05	REV A	
DRAWN BY	starl	SHEET	3/3	DWG NO.
CHECK BY		DATE	01/18/10	
APPD BY		TITLE COMPONENT VIDEO+DIGITAL AUDIO (4RCA),ONE PIECE		
		PART NO. R03-EXT-4RCA-FP-S		