

REVISIONS				
ZONE	REV	DESCRIPTION	DATE	APPROVED
	▲			
	▲			

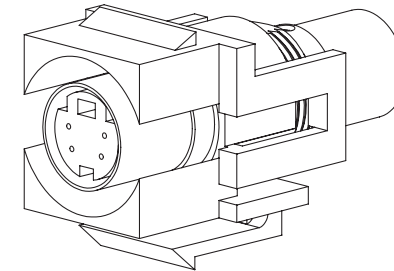

MATERIAL

Housing: ABS
 COLOR: WHITE,IVORY.....
 Temperature: -40°C ~ 68°C
 Humidity: 10% ~ 90% RH

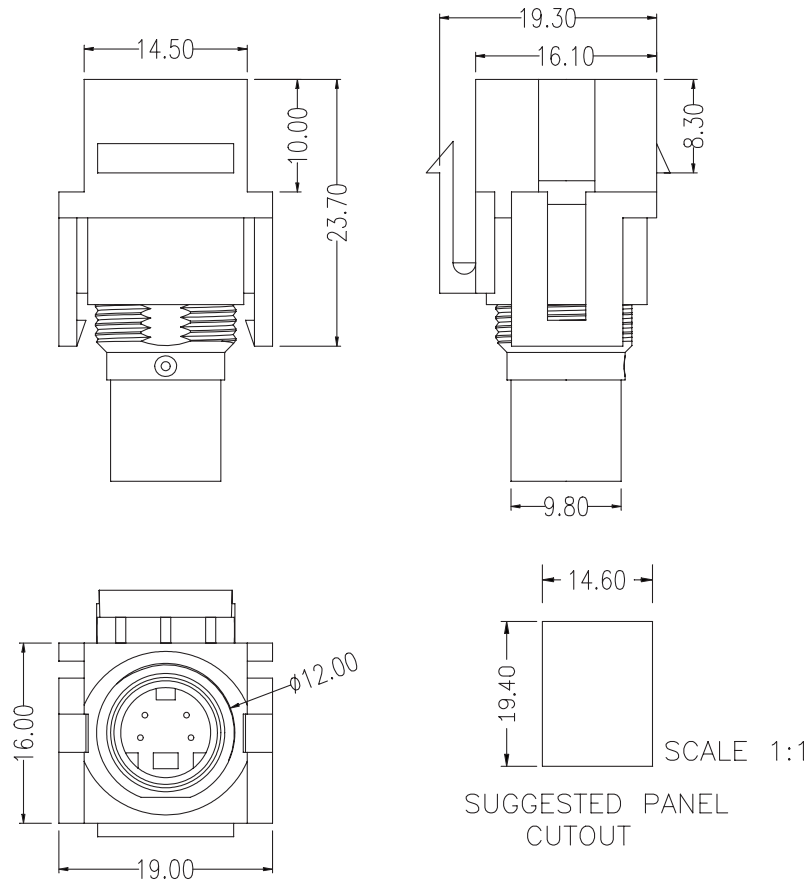

ELECTRICAL
 CONTACT RESISTANCE: 30mohm max.(INITIAL)
 INSULATION RESISTANCE: 100Mohm min. AT 500V DC.
 WITHSTANDING VOLTAGE: 500V AC FOR ONE MINUTE.
 SOLDERING HEAT TEST: 260±5°C FOR 5±1 SECONDS.
 INSERTION FORCE: 0.5~4.5 KG.
 EXTRACTION FORCE: 0.4~3.5 KG.
 LIFE TIME: 5,000 CYCLES min.



COMMON TOLERANCE			SHEET OF	ALL COPY RIGHTS RESERVED	
CLASS	A	B	SIZE	A4	 Tri-Net Technology, Inc. <i>Total Network Telesis U.S.A.</i>
DIMENSION			DIA	mm	
L<=3	±0.05	±0.1	SCALE	3:2	TITLE
3<L<=6	±0.05	±0.1	DATE	2004.10.27	071-MDIN4-XX
6<L<=16	±0.1	±0.15	DESIGN		DRAWING NO.
16<L<=30	±0.1	±0.2			D-040
30<L<=120	±0.15	±0.3	DRAWN		CHECKED
120<L<=315	±0.2	±1			