

APPROVED BY _____
 COMPANY: _____
 PURCHASING/ENGINEER: _____
 DATE: _____

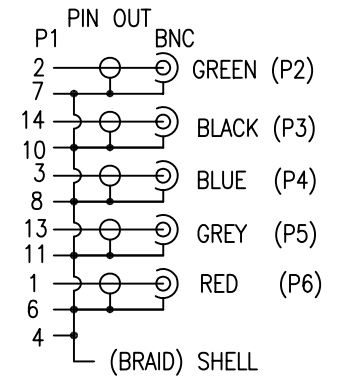

NOTE:

1. CABLE: (28AWG X 5 COAX, EACH COAX SPIRAL SHIELDED, UL1354, COLOR CODE: RED, GREEN, BLUE, GREY, BLACK), AL-FOIL AND BRAID SHIELDED WITH DRAIN, UL2919 + CUL IA FT1, BLACK PVC JACKET. $\phi 9.0 \pm 0.15$ mm.
2. CONNECTOR: P1: DIN 14P MALE, NICKEL PLATED CONTACTS AND SHELL, LOCKER TYPE. P2, P3, P4, P5, P6: BNC FEMALE WHITE INSULATOR, COPPER COVER, 75 ohm.
3. PLASTIC FACE PLATE: 6 PORTS. WHITE PAINTED.
4. P1 SHIELDED: COPPER FOIL TAPE COVER PREMOLD AND 360° SOLDER TO CONNECTOR SHELL AND CABLE BRAID.
5. DIN 14P MOLDED 45P BLACK PVC, BNC FEMALE MOLDED 25P WHITE (WH05) PVC,
6. TESTING: 100% ELECTRICAL TEST.
8. PACKING: EACH CABLE IN A BOX.
9. MOLD NO.: D14M-N01, D14M-02, BNC-N05, BNC-05, SR-01.

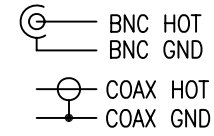

A		INITIAL RELEASE		11/24/08	
REV		DESCRIPTION OF CHANGE		DATE	
TOLERANCE			Tri-Net Technology, Inc.		
INCHES			M/M		
.X	.015	.30	http://www.trinetusa.com		
.XX	.010	.10	SCALE	NONE	REV A
.XXX	.005	.05	UNIT	MM	
DRAWN BY		Carl		SHEET 1/1	
CHECK BY				DATE 11/24/08	
APPD BY				TITLE	
				DIN 14/M TO 5BNC/F+FACE PLATE	
				PART NO.	
				EZ04-5BNC-FP	