

APPROVED BY _____
 COMPANY: _____
 PURCHASING/ENGINEER: _____
 DATE: _____

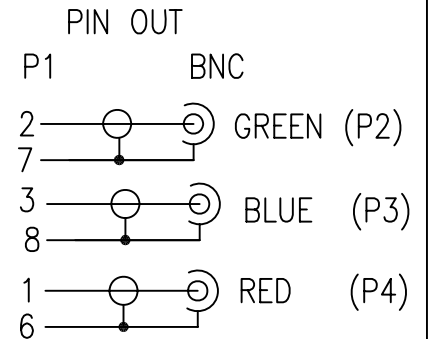

NOTE:

1. CABLE: UL2919 28AWG(7/0.127)*3COAX(OFC)+PAPER+JACKET.JACKET COLOR: BLACK MATT PVC AND OD=7.0±0.15MM.
2. CONNECTOR: P1: DIN 14P MALE, NICKEL PLATED CONTACTS AND SHELL,LOCKER TYPE. P2, P3, P4: BNC FEMALE WHITE INSULATON,COPPER COVER, 75 ohm.
3. PLASTIC FACE PATE:3PORTS.WHITE PAINTED.
4. P1 SHIELDED: COPPER FOIL TAPE COVER PREMOLD AND 360° SOLDER TO CONNECTOR SHELL AND CABLE BRAID.
5. DIN 14P MOLDED 45P BLACK PVC,BNC FEMALE MOLDED 25P WHITE(WH05) PVC,
6. TESTING: 100% ELECTRICAL TEST.
8. PACKING: EACH CABLE IN A BOX.
9. MOLD NO.: D14M-N01, D14M-02, BNC-N05,BNC-05,SR-11.

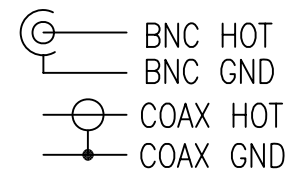

A	INITIAL RELEASE		11/24/08		
REV	DESCRIPTION OF CHANGE		DATE		
TOLERANCE			Tri-Net Technology, Inc. http://www.trinetusa.com		
.X	.015	M/M			.30
.XX	.010				.10
.XXX	.005		.05		
DRAWN BY		Carl	SHEET	1/1	
CHECK BY			DATE	11/24/08	
APPD BY			DWG NO.		
TITLE			REV A		
PART NO.			EZ04-3BNC-FP		
TITLE			DIN 14/M TO 3BNC/F+FACE PLATE		